

***Provisional** data sheets are subject to revision. The latest version is available on our website www.mactac-europe.com or on demand

Specialities: Car Protective Film CPF 60

GENERAL INTRODUCTION

PRODUCT DESCRIPTION

TYPICAL APPLICATION

RESISTANCE

SHELF LIFE

ADDITIONAL INFORMATION

Specialities

-is a range of high technology self-adhesive products, developed for specific industrial applications, particularly in the medical, optical or security fields, etc.

CPF 60 is a 55 μ white PP film coated on one side with a clear, removable solvent based pure acrylic pressure-sensitive adhesive.

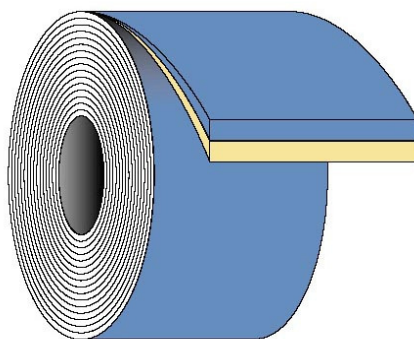

55 μ white PP film
siliconised one side

Ultra removable
Acrylic adhesive

CPF 60 does not influence the pH level of substrate to which it is applied

Short-term protection film to be applied for example on vehicles to protect the painting during transportation.

Resistant to short contact with water, detergents, alcohol and some aliphatic solvents. Not recommended for use in contact with ketones, esters, aromatic and chlorinated hydrocarbons. *For further technical advice, please consult with MACTac*

2 years when stored at 15 to 25°C and \pm 50 % relative humidity.

IMDS – automotive registration : CPF 60 has been introduced in the IMDS (International Material Data System)

Contains more than 0.1% (w/w) of Bis (2-ethyl(hexyl)phthalate) (DEHP) CAS number 117-81-7. You can find more information on this substance on

<http://www.dehp-facts.com/>

ADHESIVE DATA

	TYPICAL VALUES (*)	TEST METHOD
Peel 180° on stainless steel (N/m)		
- after 20 minutes	5	FTM 1 (ASTM D 903-49)
- after 24 hours	6	
Quick Tack on stainless steel (N/25 mm)	4,5	FTM 9
Shear on stainless steel (hours) 1kg – 25 mm x 25 mm	100	FTM 8
Dimensional stability (MD & CD)	0.1 %	FTM 14

TEMPERATURE RESISTANCE

Minimum application temperature	- 10°C to + 40°C
End-use temperature range	- 30°C to + 70°C

For temperatures outside those quoted above, please consult with MACtac.

RELEASE LINER THICKNESS (Film + Adhesive)

75 μ	ISO 534
------	---------

(*) Values given are typical and are not necessarily for use in specifications.

IMPORTANT NOTICE

All MACtac products are subject to careful quality control throughout the manufacturing process and are warranted to be of merchantable quality and free from manufacturing defects. Published information concerning MACtac products are based upon research which the Company believes to be reliable but such information do not constitute a warranty. Because of the variety of possible uses for MACtac products and the continuing development of new uses, the purchaser should carefully consider the fitness and performance of the product for each intended use and the purchaser assumes all risks in connection with such use. Seller shall not be liable for damages in excess of the purchase price of the product or for incidental or consequential damages. All specifications are subject to change without prior notice.

